

# HERNON EQUIPMENT CATALOG

December 2013





**Autobonder 2040**

400ml Dual Cartridge Dispense System  
 Dispensing machine tool used to dispense two part adhesives such as epoxy ,Tuffbond and Fusionbond.

**Hernon Part Number AUTOBONDER2040**

- Adjustable solid-state, six function timer with timing ranges from .01 seconds to 9,999 hours
- Repeat Accuracy +/-0.3%
- Offers precise dispensing for 400ml cartridge dual-component adhesives
- Offers consistent 1 to 1 ratio adhesive mixture
- Roller "Pinch Valve" creates "Pull Back" effect reducing tail off and waste.

**System Includes:**

Control Box 2111-2040  
 Foot Switch  
 Dispensing Stand  
 Interconnect Hoses & Connectors  
 Quantity 5 pt # STATIC0003 Pinch able static mixer



**Autobonder 2511**

Dispensing sealants via two reservoir and dispense valves.

**Hernon Part Number: Autobonder2511**

- Automatic coating machine with twin dispensing heads & PLC control
- Adjustable air pressure from 0-100 psi
- PLC controller and dual turntables for consistent application on circular/radial shaped parts.
- Capable of manual operation for set up
- 100% Solid-State, six function timer with timing ranges from .01 seconds to 9,999 hours
- Can be configured to hold four valves

**System Includes:**

Control Box 2511  
 Two Sureshot 2200 Valves or 4000 Valves  
 two R125 Reservoirs  
 Foot Switch  
 Interconnect Hoses & Connectors  
 Needle Kit



**Autobonder 2511-R**

Dispensing sealants via two reservoir and dispense valves.

**Heron part number: Autobonder2511R**

- Automatic coating machine with twin dispensing heads & PLC control
- Adjustable air pressure from 0-100 psi
- PLC controller and dual turntables for consistent application on circular/radial shaped parts.
- Capable of manual operation for set up
- 100% Solid-State, six function timer with timing ranges from .01 seconds to 9,999 hours
- Can be configured to hold four valves
- 2 Roller wipers

**System Includes:**

Control Box 2511  
 Two Sureshot 2200 Valves or 4000 Valves  
 two R125 Reservoirs  
 Foot Pedal ControlPT0002  
 Interconnect Hoses & Connectors  
 Needle Kit



**Autobonder 2511 Basic**

Dispensing sealants through two dispense valves for circular applications such as speakers etc.

**Heron part number: Autobonder2511 Basic**

- Autobonder 2511B
- Adjustable air pressure from 0-100psi
- 100% Solid-State, Six Function Timer with timing ranges from .01 seconds to 9,999 hours
- PLC controller and dual turntables for consistent application on circular & disc shaped parts
- Can be configured to hold four valves
- Variable control speed
- Excellent for audio speaker magnet, voice coil assembly
- Includes heavy duty slide actuator

**System Includes**

Control Box 2511  
 Foot Pedal ControlPT0002



**Autobonder 2101-H-120V**

**Hernon part number: 110-034**

**Reference Part Number: AUTO2101-H-120V**

- 0-100 psi for dispensing material of medium to high viscosity
- Vacuum "Pull Back" feature for accurate dispense volume
- Optional syringe sizes
- 100% Solid State, six function timer
- 120 Volts 60 Hertz

**System includes:**

Foot Pedal ControlPT0002  
two 30 cc dispense syringes  
aluminum syringe stand  
Interconnect hoses & connectors  
needle kit  
syringe adapter



**Autobonder 2101-L-120V**

**Hernon part number: 110-035**

**Reference Part Number: AUTO2101-L-120V**

- 0-30 psi gauge for low viscosity materials
- 100% solid state, six function timer
- Vacuum "pull back" feature for accurate dispense volume
- Optional syringe sizes
- 120 Volts 60 Hertz

**System Includes:**

Foot Pedal ControlPT0002  
two 30 cc dispensing syringes  
aluminum syringe stand  
Interconnect hoses & Connectors  
needle kit  
syringe adapter



**Autobonder 2101-H-230V**

**Hernon part number: 110-036**

**Reference Part Number: AUTO2101-H-230V**

- 0-100 psi for dispensing material of medium to high viscosity
- Vacuum "Pull Back" feature for accurate dispense volume
- Optional syringe sizes
- 100% Solid State, six function timer
- 230 Volts 50 Hertz
- **European Use**

**System includes:**

Foot Pedal ControlPT0002  
two 30 cc dispense syringes  
aluminum syringe stand  
Interconnect hoses & connectors  
needle kit  
syringe adapter



**Autobonder 2101-L-230V**

**Hernon part number: 110-037**

**Reference Part Number: AUTO2101-L-230V**

- 0-30 psi gauge for low viscosity materials
- 100% solid state, six function timer
- Vacuum "pull back" feature for accurate dispense volume
- Optional syringe sizes
- 230 Volts 50 Hertz
- **European Use**

**System Includes:**

Foot Pedal ControlPT0002  
two 30 cc dispensing syringes  
aluminum syringe stand  
Interconnect hoses & Connectors  
needle kit  
syringe adapter



**AUTOBONDER 2111-120 Kit**

**Hernon part number: 110-048**

**Reference Part Number: AUTO2111-120V**

- 0-100 psi for dispensing materials of low-medium-high viscosity materials
- excellent for most aggressive and reactive chemicals
- 100% solid state, six function timer: timing ranges from .01 seconds to 9,999 hours
- repeat accuracy 0.03 to 0.05g
- 120 Volts 60 Hertz

**System includes:**

Control box 2111

fully adjustable valve stand SS-2200-30

dispense valve Sureshot 2200 or 4000

Reservoir R125 (note: indicate high or low pressure regulator)

interconnect hoses & connectors

Foot Pedal ControlPT0002

Needle Kit NEEDLEKIT0002



**AUTOBONDER 21110-230 Kit**

**Hernon part number: 110-049**

**Reference Part Number: AUTO2111-230V**

- 0-100 psi for dispensing materials of low-medium-high viscosity materials
- excellent for most aggressive and reactive chemicals
- 100% solid state, six function timer: timing ranges from .01 seconds to 9,999 hours
- repeat accuracy 0.03 to 0.05g
- 230 Volts 50 Hertz

- **European Use**

**System includes:**

Control box 2111

fully adjustable valve stand SS-2200-30

dispense valve Sureshot 2200 or 4000

Reservoir R125 (note: indicate high or low pressure regulator)

interconnect hoses & connectors

Foot Pedal ControlPT0002

Needle Kit NEEDLEKIT0002

Note: no photo  
unit will be the same as the 2111 except:  
2111-A1000 includes a spray valve not a sure shot valve

**AUTOBONDER 2111 -A1000**  
**Hernon part number: AUTO2111-A1000**

- 0-100 psi for dispensing materials of low-medium-high viscosity materials
- excellent for most aggressive and reactive chemicals
- 100% solid state, six function timer: timing ranges from .01 seconds to 9,999 hours
- repeat accuracy 0.03 to 0.05g

**System includes:**

Control box 2111  
valve stand  
A1000 Spray Valve  
Reservoir R125 (note: indicate high or low pressure regulator)  
interconnect hoses & connectors  
Foot Pedal ControlIPT0002



**Autobonder 2600**  
**Hernon part number: AUTOSEALER2600**

- semi-automatic, fully pneumatic, portable pipe thread sealant dispensing system
- dial dispenser handles pipe diameters: 1/8", 1/4", 3/8", 1/2" & 3/4"
- easy-to-use system reduces product waste
- holds 50ml 250ml tubes of Hernon sealants

**Hernon part number: AUTOSEALER2600-850**

- semi-automatic, fully pneumatic, portable pipe thread sealant dispensing system
- dial dispenser handles pipe diameters: 1/8", 1/4", 3/8", 1/2" & 3/4"
- easy-to-use system reduces product waste
- holds 850ml cartridges of Hernon sealants



**AutoCoater 1850**

**Part number: AutoCoater 1850**

- A non-contact dispensing unit designed to apply sealant or adhesive to a bore
- It uses a small precision air motor to spin a dispersion cup or disk which is inserted into a bore
- The Sureshot valve deliver a controlled uniform bead to the inner surface of the bore
- The dispenser cup prevents over spray

**System includes:**

control box

R125 Reservoir

Foot Pedal ControlIPT0002

air motor

dispersion tip

Hernon sureshot dispensing valve

dispensing needle

needle kit



**Rambo 2010**

**Part number: RAMBO2010**

- fully pneumatic dispensing system
- repeat accuracy of +/- 0.3
- adjustable shop air pressure from 0-100 psi to create dispense pressure 350 psi
- dispenses very high viscosity adhesives and sealants such as Hernon Gasket Replacer 910
- utilizes 1,000ml poly-pak containers to minimize waste and for ease of replacement
- excellent for use in heavy volume production lines.

**System includes:**

sureshot 4000-T and hoses & connectors



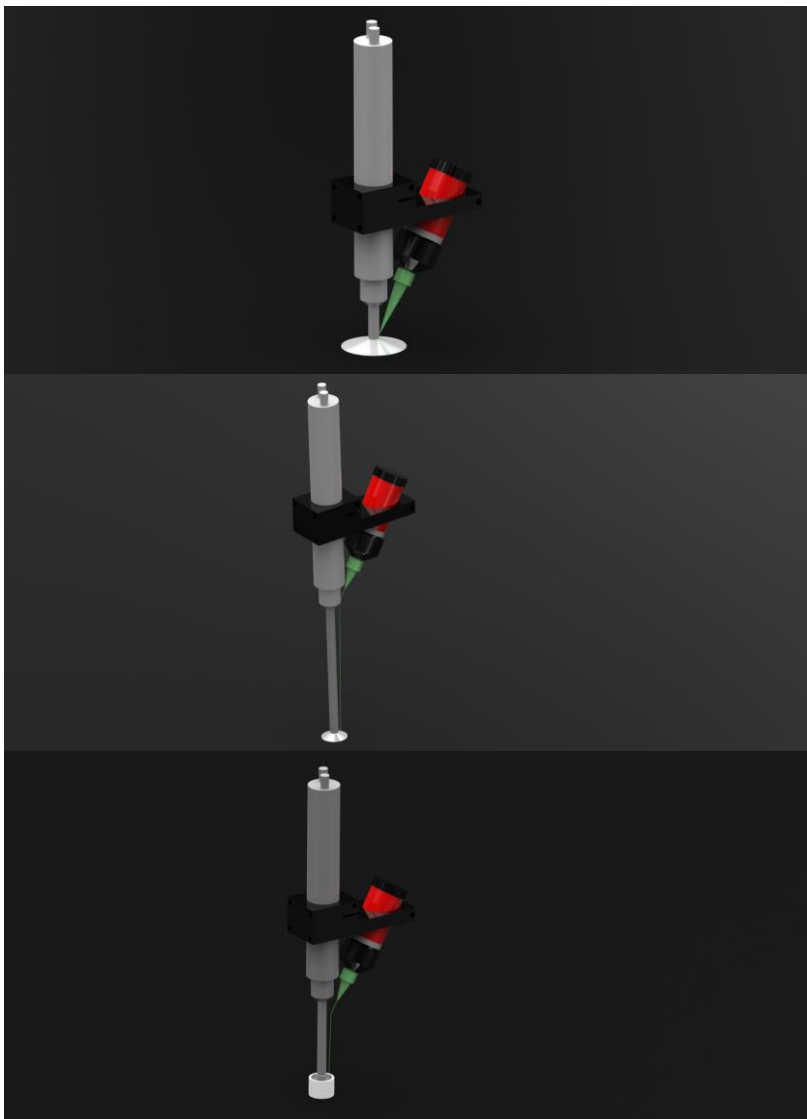

Style: A  
 Approx. 1" Bore Depth  
 Disk sizes: .75"- 2"

Style: B  
 Approx. 4" Bore Depth  
 Disk sizes: .75"- 2"

Style: C  
 Approx. 2.25" Bore Depth  
 Disk sizes: .310"- 2"

**Rotocoater 750**

**Part number: Rotocoater 750-2200**

- high speed, precise application of sealant or adhesive to bores (bores .375 dia. and up), no over spray
- short cycle times
- controlled bead width application in hard-to-reach recesses
- easy cleanup, low maintenance
- use with a variety of materials
- tip not included

**System Includes:**

Air Motor

1/4" dia spindale collet

motor mounting bracket

Sureshot 2200 dispense valve

**Needle Kit Style A:** Needle Kit 2 **Style B&C:** Needle kit 4

Style: A  
 Approx. 2" Bore Depth  
 Disk sizes: .250"- .500"

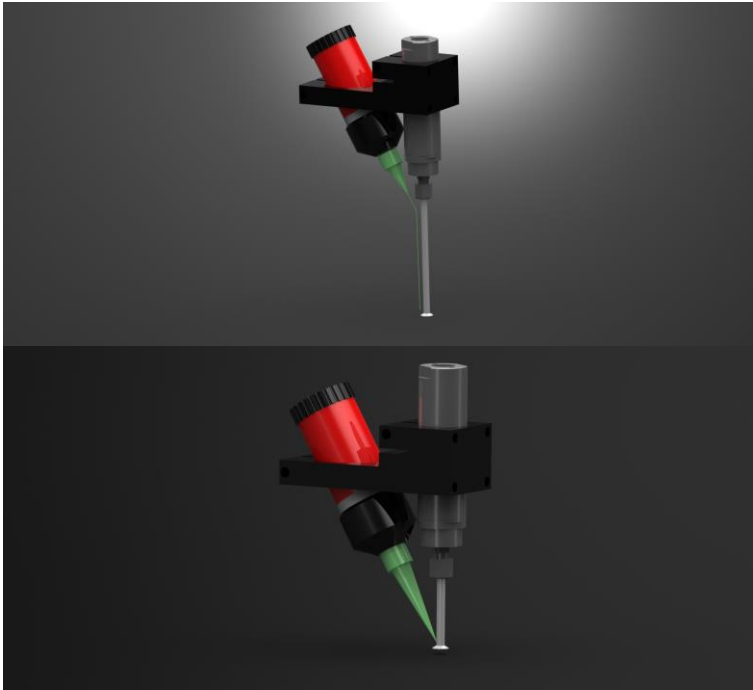

Style: B  
Approx. 1" Bore Depth  
Disk sizes: .250" - .500"

**RotoCoater RC500-2200**

**Part number: RotoCoater RC500-2200**

- A non-contract dispensing unit designed to apply sealant or adhesive to a bore (bore dia. 1/4"-3/4")
- It uses a small precision air motor to spin a dispersion disk which is inserted into a bore.
- The Sureshot valve delivers a controlled uniform bead to the inner surface of the bore

**System includes:**

air motor

dispersion tip

Heron Sureshot dispensing valve

dispensing needle

Needle kit

Style A: Needle Kit 4

Style B: Needle Kit 0002

# ROTOCOATER 500 STYLE: A

TABLE 2 DISKS WORK WITH TABLE 1 NEEDLE SERIES  
DESIGNED FOR USE WITH ROTOCOATER 500

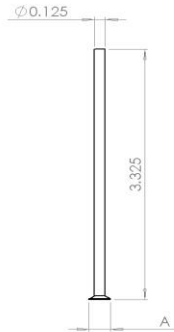

NOTE: SEE TABLE 2 FOR A

## NEEDLE KIT 4

NEEDLE GAGE	NEEDLE COLOR	NEEDLE NUMBER
14	GREEN	RC-NEEDLE14SS
15	ORANGE	RC-NEEDLE15SS
16	LIGHT PURPLE	RC-NEEDLE16SS
18	LIGHT GREEN	RC-NEEDLE18SS
21	DARK PURPLE	RC-NEEDLE21SS
23	LIGHT ORANGE	RC-NEEDLE23SS

SPINNER DIAMETER	SPINNER NUMBER
.250	TIPR-RC500-250
.312	TIPR-RC500-312
.375	TIPR-RC500-375
.500	TIPR-RC500-500

## RotoCoater 500 Style: A Tips

### Tip sizes:

- TIPRS-RC500-0250
- TIPRS-RC500-0312
- TIPRS-RC500-0375
- TIPRS-RC500-0500

### Part number: ROTOCOATERTIP

- dispersion disk tool

# ROTOCOATER 500 STYLE: B

TABLE 2 DISKS WORK WITH TABLE 1 NEEDLE SERIES  
DESIGNED FOR USE WITH ROTOCOATER 500

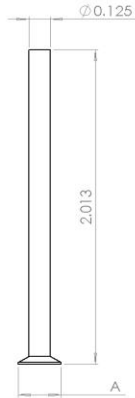

NOTE: SEE TABLE 2 FOR A

## NEEDLE KIT 2

TABLE 1		
MICROTIP GAGE	MICROTIP COLOR	MICROTIP NUMBER
14	ORANGE	MICROTIP14
16	GRAY	MICROTIP16
18	GREEN	MICROTIP18
20	PINK	MICROTIP20
22	LIGHT BLUE	MICROTIP22
24	GRAY	MICROTIP24



TABLE 2	
SPINNER DIAMETER	SPINNER NUMBER
.250	TIPR-RC500-S250
.312	TIPR-RC500-S312
.375	TIPR-RC500-S375
.500	TIPR-RC500-S500



## RotoCoater 500 Style: B Tips

### Tip sizes:

- TIPRS-RC500-S0250
- TIPRS-RC500-S0312
- TIPRS-RC500-S0375
- TIPRS-RC500-S0500

### Part number: ROTOCOATERTIP

- dispersion disk tool

## ROTOCOATER 750 STYLE: A

TABLE 1 DISKS WORK WITH TABLE 2 NEEDLE SERIES  
DESIGNED FOR USE WITH ROTOCOATER 750

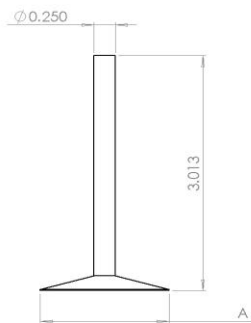

NOTE: SEE TABLE 1 FOR A

TABLE #1	
SPINNER DIAMETER	SPINNER NUMBER
.75	TIPRS-RC750-0750
1.250	TIPRS-RC750-1250
1.500	TIPRS-RC750-1500
1.500	TIPRS-RC750-1550
2.000	TIPRS-RC750-2000

NEEDLE KIT 2		
TABLE #2		
MICROTIP GAGE	MICROTIP COLOR	MICROTIP NUMBER
14	ORANGE	MICROTIP14
16	GRAY	MICROTIP16
18	GREEN	MICROTIP18
20	PINK	MICROTIP20
22	LIGHT BLUE	MICROTIP22
24	RED	MICROTIP24

### RotoCoater 750 Style: A Tips

Tip Sizes	Part Number	Reference Part Number
3/4"	106-056	TIPRS-RC750-0750
1"	106-057	TIPRS-RC750-1000
1 1/4"	106-058	TIPRS-RC750-1250
1 1/2"	106-059	TIPRS-RC750-1500
2"	106-061	TIPRS-RC750-2000

### Part number: ROTOCOATERTIP

- dispersion disk tool

## ROTOCOATER 750 STYLE: B

TABLE 1 DISKS WORK WITH TABLE 2 NEEDLE SERIES  
DESIGNED FOR USE WITH ROTOCOATER 750

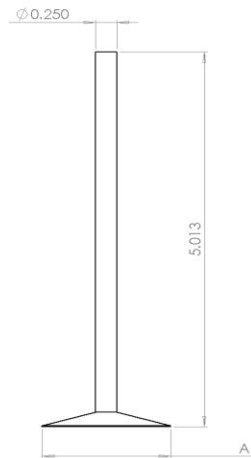

NOTE: SEE TABLE 1 FOR A

TABLE 1	
SPINNER DIAMETER	SPINNER NUMBER
.75	TIPRS-RC750-0750
1.000	TIPRS-RC750-1000
1.000	TIPRS-RC750-1000XL
1.250	TIPRS-RC750-1250
1.500	TIPRS-RC750-1500
2.000	TIPRS-RC750-2000

NEEDLE KIT 4	
TABLE 2	
TEFLON LINED ID	FEED TUBE NUMBER
.095	HFT-1008
.095	HFT-1010

### RotoCoater 750 Style: B Tips

#### Tip sizes:

TIPRS-RC750-0750

TIPRS-RC750-1000

**TIPRS-RC750-1000XL**

TIPRS-RC750-1250

TIPRS-RC750-1500

TIPRS-RC750-2000

#### Part number: ROTOCOATERTIP

- dispersion disk tool

# ROTOCOATER 750 STYLE: C

TABLE 1 CUPS WORK WITH TABLE 2 NEEDLE SERIES  
DESIGNED FOR USE WITH ROTOCOATER 750

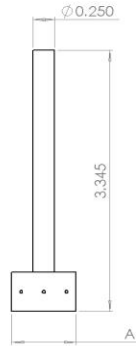

NOTE: SEE TABLE 1 FOR A

TABLE 1	
CUP DIAMETER	CUP NUMBER
.310	TIPR-RC750-0310
.375	TIPR-RC750-0375
.500	TIPR-RC750-0500
.625	TIPR-RC750-0625
.700	TIPR-RC750-700
.750	TIPR-RC750-750
1.000	TIPR-RC750-1000
1.125	TIPR-RC750-1250
1.500	TIPR-RC750-1500
2.000	TIPR-RC750-2000

NEEDLE KIT 4

TABLE 2		
NEEDLE GAGE	NEEDLE COLOR	NEEDLE NUMBER
14	GREEN	RC-NEEDLE14SS
15	ORANGE	RC-NEEDLE15SS
16	LIGHT PURPLE	RC-NEEDLE16SS
18	LIGHT GREEN	RC-NEEDLE18SS
21	DARK PURPLE	RC-NEEDLE21SS
23	LIGHT ORANGE	RC-NEEDLE23SS

## RotoCoater 750 Style: C Tips

### Tip sizes:

TIPR-RC750-0310  
 TIPR-RC750-0375  
 TIPR-RC750-0500  
 TIPR-RC750-0625  
 TIPR-RC750-0700  
 TIPR-RC750-0750  
 TIPR-RC750-1000  
 TIPR-RC750-1250  
 TIPR-RC750-1500  
 TIPR-RC750-2000

### Part number: ROTOCOATERTIP

- dispersion cup tool

**Sureshot 2200**



**Sureshot 2200**

**Part number: 110-000**

**Reference Part Number: SS-2200**

- Delrin Manifold/Teflon diaphragm
- Normally closed valve, pneumatically actuated
- 70 PSI air actuation input
- 70 PSI max. fluid/adhesive
- Precision flow metering control knob

**System includes:**

1/4-28 X Luer-lock Adapter

18" npt X 1/4" tube X 90 degree Kynar fluid fitting

**Sure shot 2200 (90°).**



**Sure shot 2200 (90°)**

**Part number: 110-001**

**Reference Part Number: SS-2200-90**

- Delrin Manifold, 90 degrees Teflon diaphragm
- normally closed valve, pneumatically actuated
- 70 PSI air actuation input
- 70 PSI max fluid/adhesive
- Precision flow metering control knob

**System includes:**

1/4-38 X Luer-lock Adapter, 1/8" npt X 1/4" tube X 90° Kynar fluid

1/8" npt X 1/4" tube X 90 degree Kynar fluid fitting



**Sureshot 2200 (Teflon Straight)**

**Part number: 110-003**

**Reference Part Number: SS-2200-T**

- Teflon manifold/Teflon diaphragm
- normally closed valve, pneumatically actuated
- 70 PSI air actuation input
- 70 PSI max. fluid/adhesive
- precision flow metering control knob

**System includes:**

1/4-28 X Luer-lock Adapter

1/8" npt X 1/4" tube X 90° Kynar fluid fitting

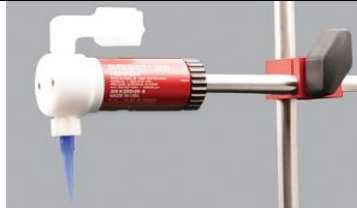

**Sureshot 2200 (Teflon 90°)**

**Part number: 110-002**

**Reference Part Number: SS-2200-90-T**

- Teflon manifold, 90° Teflon diaphragm
- normally closed valve, pneumatically actuated
- 70 PSI air actuation input
- 70 PSI max fluid/adhesive
- Precision flow metering control knob

**System includes:**

1/4-38 X Luer-lock Adapter, 1/8" npt X 1/4" tube X 90° Kynar fluid

1/8" npt X 1/4" tube X 90 degree Kynar fluid fitting



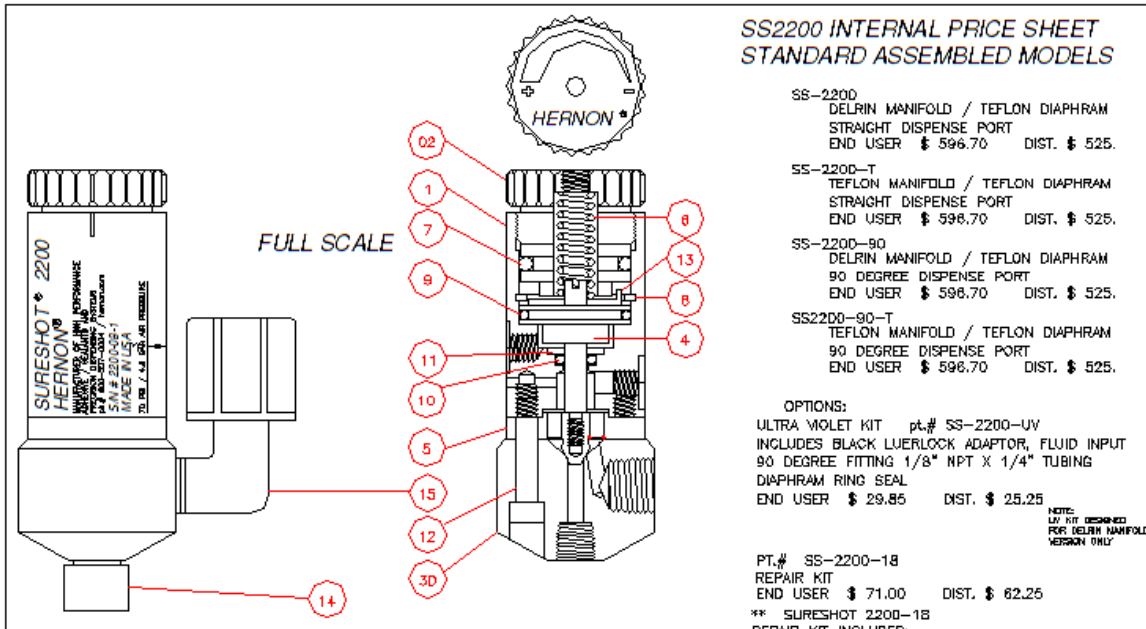

**SS2200 COMPONENTS PRICES**

QTY	HERNON PART #	DESCRIPTION	DISTRIBUTOR PRICE	END USER PRICE
21	SS2200-21	OPTIONAL BLK 1/4-28 LUERLOCK ADAPTOR ( EFD PT.# 7014838 ) \$ 4.34 EACH	\$ 18.50	\$ 21.00
20	SS2200-20	OPTIONAL BLK 1/8-NPTx1/4" TUBING 90 DEGREE NYLON ( EFD PT.# 7543BP ) \$ 9.75	\$ 36.50	\$ 42.00
19	SS2200-19	OPTIONAL DIAPHRAM COVER RING FOR UV APPLICATIONS	\$ 22.00	\$ 25.00
18	SS2200-18	SURESHOT 2200 - DIAPHRAM / SEAL KIT	\$ 62.25	\$ 71.00
17	SS2200-17	OPTIONAL V TYPE MOUNTING BRACKET / 1032 x 1/2" LG FH	\$ 27.50	\$ 32.00
16	SS2200-16	OPTIONAL .375" DIA. X 4" X 10-32 VALVE MOUNTING POST	\$ 30.00	\$ 34.00
** 15	SS2200-15	1/8-NPT X 1/4" TUBING 90 DEGREE KYNAR FIT 1/8-1/4-90	\$ 6.30	\$ 7.21
** 14	SS2200-14	1/4-28 LUERLOCK NEEDLE ADAPTOR # ADAPTOR015	\$ 2.00	\$ 2.40
13	SS2200-13	KEYED WASHER SPECIAL	\$ 15.25	\$ 17.50
12	SS2200-12	6-32 X 3/4" LG. S.H.C.S. S.S.	\$ 2.10	\$ 2.50
11	SS2200-11	#8 SS WASHER .3750Dx5/32IDx .03	\$ 2.10	\$ 2.50
** 10	SS2200-10	9/320Dx5/32ID BUNA ORING # 007	\$ 2.10	\$ 2.50
** 09	SS2200-9	3/40Dx5/8ID BUNA ORING # 016	\$ 2.10	\$ 2.50
08	SS2200-8	SS INTERNAL RETAINING RING	\$ 6.40	\$ 9.50
** 07	SS2200-7	11/16" OD x 1/2" ID BUNA ORING #112	\$ 2.10	\$ 2.50
06	SS2200-6	SPRING .296 DIA. x .98 LG. x .043 WIRE # HB2-29	\$ 15.75	\$ 18.00
** 05	SS2200-5	DIAPHRAM TEFLON	\$ 81.00	\$ 93.00
04	SS2200-4	PISTON	\$ 84.00	\$ 95.00
3*	SS2200-3TL	MANIFOLD BLACK TEFLON 90 DEGREE	\$ 109.00	\$ 124.00
3*	SS2200-3T	MANIFOLD BLACK TEFLON STRAIGHT	\$ 109.00	\$ 124.00
3*	SS2200-3DL	MANIFOLD BLACK DELRIN 90 DEGREE	\$ 109.00	\$ 124.00
3*	SS2200-3D	MANIFOLD BLACK DELRIN STANDARD STRAIGHT	\$ 109.00	\$ 124.00
02	SS2200-2	FLOW ADJUSTER KNOB	\$ 101.00	\$ 115.00
01	SS2200-1	VALVE BODY	\$ 151.00	\$ 172.00

**HERNON MANUFACTURING**

PH.# 800-527-0004 / 407-322-4000 / www.hernon.com

DRAWN T.J.B.10-28-07		SURESHOT 2200 INTERNAL PRICE SHEET	
DO NOT SCALE			
TOLERANCES UNLESS OTHERWISE NOTED FRACTIONS +/- .015 2 DECIMAL +/- .005 3 DECIMAL +/- .0015 4 DECIMAL +/- .0005 ANGLES +/- 1/2°	SIZE A	DRAWING NO. SS2200	
	SCALE FULL	UNLESS OTHERWISE NOTED BREAK ALL SHARP EDGES CHAMFER ALL HOLES .01 x 45 DEG.	SHEET PRICE

HERNON RESERVES THE RIGHT TO CHANGE THIS DRAWING AT ANYTIME FOR ANY REASON.



**Sureshot 2200 repair kit**

**Part number: 110-029**

**Reference Part Number: SS-2200-18**

- Teflon diaphragm, o-ring seals, LUER-lock Adapter and 1/8" NPT X 90° Kynar fitting
- O-ring seals



**Sureshot 2200 UV Conversion Kit**

- The ultraviolet conversion kit should be used when the valve is controlling and dispensing ultraviolet adhesives and sealants
- UV conversion kit is designed for Sureshot model number SS-2200 & SS-2200-90 which have a black Delrin manifold

**Part number: 110-030**

**Reference Part Number: SS-2200-UV**

**System includes:**

- diaphragm UV guard ring
- black LUER-lock Adapter
- black 1/8" NPT x 1/4" tube X 90° fluid connect fitting
- diaphragm ring



**Sureshot 2200 V mounting block**

- Optional V block mount for sureshot 2200 dispense valve

**Hernon part number: 106-033**

**Reference Part Number: SS-2200-17**



**Sureshot 2200 mounting rod**

- 3/8"/.375" dia. x 4" lg stainless steel rod

**Hernon part number: 106-032**

**Reference Part Number: SS-2200-16**



**Dispensing Valve**

**Part number: 103-005**

**Reference Part Number: VALVE0003**

- Plastic with Teflon diameter shot valve-1/2" NPT
- Inlet for high low viscosity materials



**Dispensing Valve**

**Part number: 103-006**

**Reference Part Number: VALVE0004**

- Plastic with Teflon diameter shot valve-1/4" NPT
- Inlet for high low viscosity materials



**Repair Kit Sureshot 2000 dispensing valve**

**Part number: 110-038**

**Reference Part Number: SURESHOT2000/R-Kit**

- Repair Kit Sureshot 2000 dispensing valves



**Repair Kit Sureshot 4000 dispensing valve**

**Part number: 110-032**

**Reference Part Number: SURESHOT4000/R-Kit**

- Repair Kit Sureshot 4000 dispensing valves



**Sureshot 4000**

**Hernon part number: 110-005**

**Reference Part Number: SURESHOT4000**

- Pneumatic dispensing valve for high-flow, high viscosity materials
- 1/8" NPT air input
- Constructed of anodized aluminum for wetted compounds:
- "Pull Back" feature eliminates waste
- Withstands fluid pressure to 450 psi
- 1/4" NPT fluid connect
- Excellent for manual or automated production
- Uses standard LUER-lock needles
- Comes with an aluminum piston



**Sureshot 4000-T**

**Hernon part number: 110-006**

**Reference Part Number: SURESHOT4000-T**

- Pneumatic dispensing valve for high-flow, high anaerobic materials
- 1/8" NPT air input
- Constructed of anodized aluminum for wetted compounds:
- "Pull Back" feature eliminates waste
- Withstands fluid pressure to 450 psi
- 1/4" NPT fluid connect
- Excellent for manual or automated production
- Uses standard LUER-lock needles
- Comes with a teflon piston



**Part number: 110-007**

**Reference Part Number: SURESHOT4000L**

- 90% pneumatic dispensing valve for high-flow, high- viscosity materials
- Constructed of aluminum and Teflon for wetted compounds:
- "Pull Back" feature eliminates waste
- Withstands fluid pressure to 450 psi
- Excellent for manual or automated production
- Uses standard LUER-lock needles

**System includes**

Hernon Quick Disconnect

1/8" NPT



**Part number: AUTOBONDER2020**

- Integrated servo controller for SS3000/3200 Pumps

**System includes**

- AB202 Control Box
- PLC-controlled
- Integrated servo controller
- 2020 w/ sureshot 3000/3200
- Sureshot 3000
  - Titanium Nitrate Coated 316 S.S. (Gold)
  - 6061T611 Aluminum (Black)
  - Offered in 1/4" and 3/8" Pistons
- Sureshot 3200 – (Red) 3/16" Piston
- Sureshot3000 spare parts lists shown on next page



**1/4" Sureshot 3000 Repair Kit**

**Part number: 110-069**

- SS3000 Repair Kit

**System includes**

- 2 1/4" ID Rulon Piston Seal
- 2 Teflon Port Seal
- 1 Teflon Head Seal
- 1 1/4" ID Teflon Gland Washer



**3/8" Sureshot 3000 Repair Kit**

**Part number: 110-070**

- SS3000 Repair Kit

**System includes**

- 2 3/8" ID Rulon Piston Seal
- 2 Teflon Port Seal
- 1 Teflon Head Seal
- 1 3/8" ID Teflon Gland Washer

# SURESHOT 3000 PARTS LIST

SS3000 1/4" AND 3/8" DIA. PISTONS PRICE SHEET ASSEMBLED COMPONENTS LIST FOR STANDARD ASSEMBLY MODELS

DIGITAL DISPENSE WITH 1/4" PISTON ALUMINUM HOUSING  
- PT.# 110-061

ASSEMBLED COMPLETE WITHOUT ROTATING COUPLING  
**DISTRIBUTOR: \$995.00 END USER: \$1,145.00**

DIGITAL DISPENSE WITH 3/8" PISTON ALUMINUM HOUSING  
- PT.# 110-062

ASSEMBLED COMPLETE WITHOUT ROTATING COUPLING  
**DISTRIBUTOR: \$995.00 END USER: \$1,145.00**

DIGITAL DISPENSE WITH 1/4" PISTON STAINLESS STEEL HOUSING  
- PT.# 110-063

ASSEMBLED COMPLETE WITHOUT ROTATING COUPLING  
**DISTRIBUTOR: \$995.00 END USER: \$1,345.00**

DIGITAL DISPENSE WITH 3/8" PISTON STAINLESS STEEL HOUSING  
- PT.# 110-064

ASSEMBLED COMPLETE WITHOUT ROTATING COUPLING  
**DISTRIBUTOR: \$995.00 END USER: \$1,345.00**

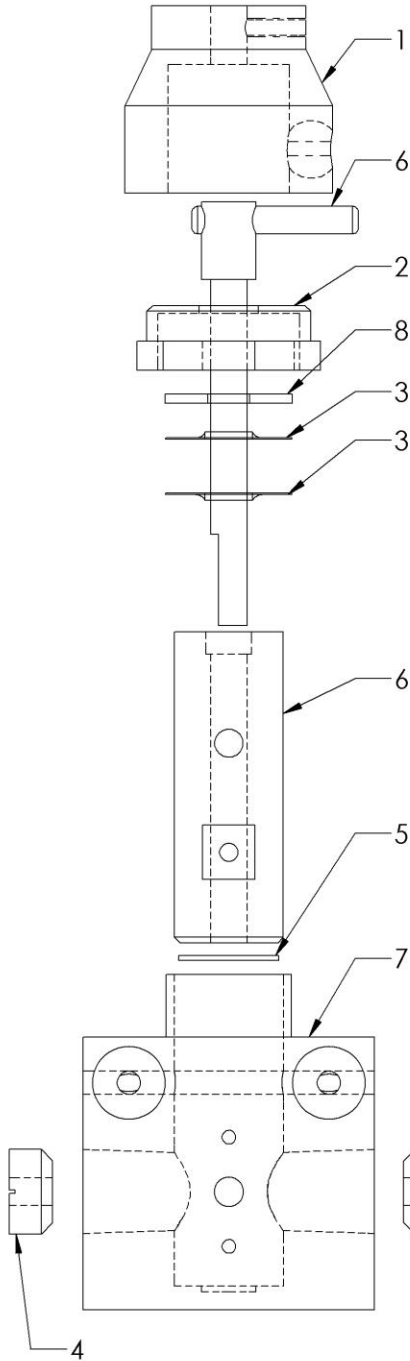

ITEM	QTY	HERNON PT.#	DESCRIPTION	DISTRIBUTOR PRICE	END USER PRICE
9	6	101-008	10-32 TAPERED THREAD PLUG	\$0.20	\$0.22
8B	1	109-043	3/8" ID TEFLON GLAND WASHER	\$9.50	\$10.75
8A	1	109-046	1/4" ID TEFLON GLAND WASHER	\$9.50	\$10.75
7B	1	106-109	STAINLESS STEEL PUMP BODY	\$395.00	\$449.00
7A	1	106-110	ANOZIDED ALUMINUM PUMP BODY	\$280.00	\$325.00
6B	1	105-001	3/8" DIA. ALUMINA PISTON & LINEAR SET	\$630.00	\$708.00
6A	1	105-002	1/4" DIA. ALUMINA PISTON & LINEAR SET	\$630.00	\$708.00
5	1	109-039	TEFLON HEAD SEAL	\$9.00	\$10.20
4	2	109-044	TEFLON PORT SEAL	\$12.00	\$13.75
3B	2	109-040	3/8" ID RULON PISTON SEAL	\$9.50	\$10.75
3A	2	109-042	1/4" ID RULON PISTON SEAL	\$9.50	\$10.75
2	1	109-045	SS NUT FOR RETAINING PUMP PISTON & SEALS	\$101.00	\$115.00
1	1	109-041	ROTATING COUPLING 1/4" ID	\$143.00	\$164.00

DO NOT SCALE DRAWING		REVISION
<b>HERNON MANUFACTURING</b>		
TITLE: <b>SS3000 PRICE SHEET</b>		
DWG NO. <b>SS3000-1</b>	A4	
SCALE:1:2	SHEET 1 OF 1	

## Sureshot3500

**Part Number: 110-046**

**Reference Part Number: SS3500-150-24**

- One 24v Jetting device 150 Micron Orifice/ 1 Foot Cord

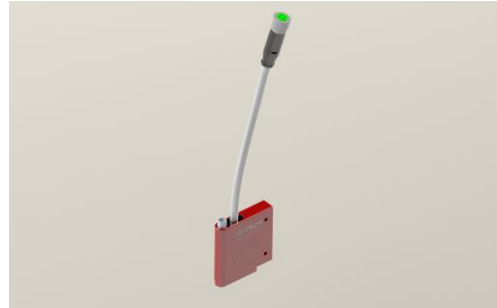

## Sureshot3500 Tubing

**Part Number: 101-035**

- 1/8" OD Long Black Teflon Tubing 250 PSI
- Buy by the foot.



## Sureshot3500 Filter

**Part Number: 107-015**

**Reference Part Number: SS3500-12M**

- 6-40 Inline 12 micron filter



## Sureshot3500 10 Micron Filter

**Part Number: 109-056**

- 10 Micron filter for use inside the R125 or first filter on the line.
- Change every 8-12 Liters





### Sureshot3500 6-40 X .085 Barbed Fitting

Part Number: 109-055

- Barbed fitting for tubing attachment into system



### Sureshot3500 Tubing “Earclamps”

Part Number: 109-054

- Tubing Fastener



### Sureshot 3500 Controller-1

Part Number: 110-058

Reference Part Number: **SS3500-CKT1-120**

- Enclosure with color touch screen PLC 100-240 VAC 50/60Hz
- Manual and auto start Pb
- Foot switch
- Timing – Dispense pulse timing in Microseconds
- No Jet Included
- Controls up to one jetting driver circuitboards / 1x Sureshot 3500



## Sureshot 3500 Controller-2

**Part Number: 110-059**

**Reference Part Number: SS3500-CKT2-120**

- Enclosure with color touch screen PLC 100-240 VAC 50/60Hz
- Manual and auto start Pb
- Foot switch
- Timing – Dispense pulse timing in Microseconds
- Not Jet Included
- Controls up to two jetting driver circuitboards / 2x Sureshot 3500



## 10 FT Sureshot 3500 Control Cord

**Part Number: 102-043**

- Male / Female
- 3 Pin / 3 Meters Long



**Ultraspot 1000**

**Part Number: 110-004**

**Reference Part Number: ULTRASPOT 1000**

- 200 watt U.V. spot curing
- Power Supply/Glasses
- Foot Switch PLC User
- Interface/ I/O Communications



**Filter Replacement Media**

**Part Number: 107-004**

**Reference Part Number: US1000-23**

- Pack of 5 pcs.

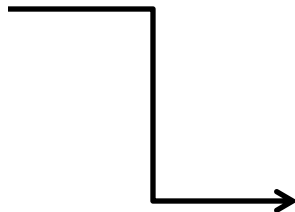

**Ultraspot 1000 Lamp 200 Watt**

**Part Number: 102-000**

**Reference Part Number: US1000-10**



**Ushio# SMR-201-UV1**

**IR Filter UVA Only (Option)**

**Part Number: 107-001**

**Reference Part Number: US1000-25**



**Lumatex Part Number: Q2.ø241**

**IR Filter UVA+Blue (Standard)**

**Part Number: 107-000**

**Reference Part Number: US1000-26**



**Main Fuse – 4 AMP Slow Blow**

**Part Number: 102-028**

**Reference Part Number: US1000-30**

- US1000-30 2 Pack

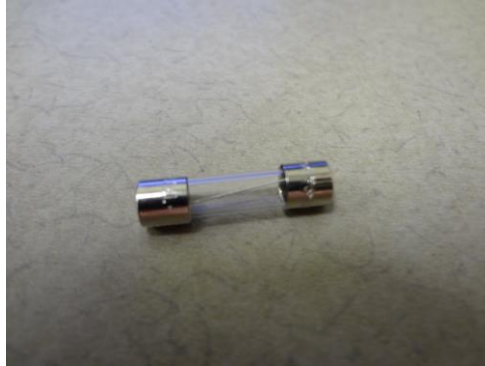

**US1000 Safety Glasses**

**Part Number: 107-005**

**Reference Part Number: US1000-45**

- Safety Glasses Shade 5 Green



**5mm Liquid Optic Wand**

**Part Number: 107-003**

**Reference Part Number: US1000-22**

- 1 meter long



**8mm Liquid Optic Wand**

**Part Number: 107-002**

**Reference Part Number: US1000-21**

- 1 meter long



**Dual 3mm Wand for use with Ultraspot 500 & Ultraspot 1000**

**Part Number: 107-009**

**Reference Part Number: US1000-42**



**Liquid Optic Wand**

**Part Number: 107-010**

**Reference Part Number: US1000-33**

- 5mm x 1500mm (59" LG.)



**Liquid Optic Wand**

**Part Number: 107-011**

**Reference Part Number: US1000-34**

- 8mm x 1500mm (59" LG)



### Lineshot1000

**Part Number: US1000-24**

**Reference Part Number: US1000-24**

- U.V. Beam Adaptor – Lineshot1000
- 8mm Diameter Wand to 10.8" Linear



### 6 Ended Lineshot Wand

**Part Number: 107-006**

**Reference Part Number: US1000-43**

- 6 2" long Lineshot
- 12" total of fiber optic wand X 36" in Length



### Lineshot 3400

**Part Number: 107-008**

**Reference Part Number: US1000-47**

- 3.4" long inline array/wand 30" Lg.
- U.V. Array 3.4" LG. x 30" Long Wand Fiber Optic



### LED UV Lineshot .28" x 4" Array

**Part Number: 107-018**

- 365nm High Output LED
- 24 vdc input power
- Built in power regulation and over temperature protection
- Does not include power supply



Hernon Vendor / pt.# Pro-Photonixs/# 750-0008

**Optical Wand Stand 5mm**

**Part Number: 110-041**

**Reference Part Number: SS-2200-30-5UV**

- Stand for US1000 Wand 5mm and 8mm



**Radiometer for Measuring U.V. Power of Spot U.V. Units US 500 & US 1000**

**Part Number: 107-012**

**Reference Part Number: Radiometer 002**

**Vendor EIT Part Number: SPI-365-EIT**



**Ultracure-21**

**Part number : 110-008**

**Reference Part Number: ULTRACURE21**

- Miniature UV Inspection Light
- UV LED / 365 nm
- includes 2 AA batteries
- 20 milliwatts per cm<sup>2</sup>





**Ultracure-100**

**Part number: 110-010**

**Reference Part Number: Ultracure-100**

- 100 watt mercury lamp unit
- 120V, 50/60 Hz internal power supply
- 4" lamp arc length
- Compact & lightweight, excellent portability
- Instructions included



**Ultracure-100-A**

**Part number: 110-011**

**Reference Part Number: Ultracure100A**

- 100 watt mercury lamp unit
- 220V, 50/60 Hz internal power supply
- 4" lamp arc length
- Compact & lightweight, excellent portability
- Instructions included



**Ultracure 200**

**Part Number: 110-012**

**Reference Part Number: ULTRA200**

- 1,000 watt, 200wpi mercury UV curing lamp unit
- 120V, 60Hz, 12 amp remote power supply
- 5" lamp length, non-focused, half-round reflector
- Instructions included



**Ultracure 200-220V**

**Part Number: 110-013**

**Reference Part Number: ULTRA200-F-50**

- 1,000 watt, 200wpi mercury UV curing lamp unit
- 220V, 50Hz, 12 amp remote power supply
- 5" lamp length, non-focused, half-round reflector
- 4' power cord without plug
- Instructions included





**Ultracure 300**

**Part number: 110-014,110-015**

**Reference Part Number: ULTRA300**

- 1,000 watt, 200 wpi mercury UV curing lamp unit
- 120V, 60 Hz, 16 amp remote power supply
- 5" lamp arc length, adjustable & focused light reflector
- Instructions included



**Ultracure 400**

**Part number: 110-016, 110-017**

**Reference Part Number: ULTRA400**

- 1,000 watt, 300 wpi mercury UV curing lamp unit
- 120V, 60 Hz, 16 amp remote power supply
- 5" lamp arc length, adjustable & focused light reflector
- Instructions included



**Ultracure 500-A**

**Part number: 110-018, 110-019**

**Reference Part Number: ULTRA500A**

- 1,600 watt, 300 wpi mercury UV curing lamp unit
- 120V, 60 Hz, 16 amp remote power supply
- 8" lamp arc length, adjustable & focused light reflector
- Instructions included



**Ultra-conveyor 1000**

**Part number: 110-024**

**Reference Part Number: ULTRACON1000**

- 100% Solid-State bench top conveyor unit for use with the Ultracure 1000 & 2000 UV curing systems
- Can hold substrates up to 7.5" x 3", with a cure area up to 6" x 3"
- 6" lamp arc width-fully rotatable lamp position to 360 degrees (100mm beyond focus)
- Internal cooling fan
- Seamless belt constructed of Kevlar coated Teflon for smooth performance & reduced static charges
- 4 standard speed ranges, 2 belt rotation cw/ccw
- Contact Heron for more information
- DOES NOT INCLUDE LIGHT SOURCE



**Ultracure 1000**

**Part Number: 110-025 (P300MT Power Supply)**

**Part Number: 110-026 (P300MQ Power Supply)**

**Reference Part Number: ULTRA1000**

- 1,800 watt, 300 wpi mercury UV curing lamp unit
- 100% Solid-State PLC control
- 208V, 50/60 hz, 18 amp, one phase remote power supply
- 6" lamp arc length, semi-elliptical focus at 2.1" (53.3mm from irradiator face)
- Internal cooling fan
- Can be used alone or in conjunction with Ultra-Conveyor 1000
- Includes Electrode less D-Bulb and instruction manual



**Ultracure 2000**

**Part number: 110-027**

**Reference Part Number: ULTRA2000**

- 2,800 watt, 500 wpi, electrode less, microwave powered UV irradiator
- 100% Solid-State PLC control
- 200-240/380-415/440-480V, 50/60HZ 18 amp, three-phase remote power supply
- 6" lamp arc length, semi-elliptical focus at 2.1" (53.3mm from irradiator face)
- Internal cooling fan
- Can be used alone or in conjunction with the Ultra-Conveyor 1000
- Includes electrode less D-Bulb and Instruction Manual



**UV Replacement Lamp - 100 Watt**

**Part Number: 102-049**

**Reference Part Number: ULTRAPT0001-A**

- 100 Watt replacement spot lamp for the Ultracure 100
- 220V
- Lamp life approximately 1,000 hours (Based on three starts per day)



**UV Replacement Lamp - Ultracure**

**Part Number: 102-045**

**Reference Part Number: ULTRAPT0002**

- 200 wpi, 5" arc/10 replacement Lamp for the Ultracure 200
- Lamp life is approximately 1,000 hours (Based on three starts per day)



**UV Replacement Lamp - Ultracure**

**Part number: 102-046**

**Reference Part Number: ULTRAPT50C**

- 300 wpi, 5" arc/13" replacement lamp for the Ultracure 400
- Lamp life is approximately 1,000 hours (Based on three starts per day)



**Replacement LAMP FOR ULTRA SPOT 500**

**Part number: 102-048**

**Reference Part Number: ULTRAPT500**



**UV Replacement Lamp - Ultracure 1000 and 2000**

**Part number: 102-050**

**Reference Part Number: ULTRAPT1000-D, ULTRA2000-D**

- electrode less type d bulb designed for use with Ultracure 1000 & 2000 UV Curing Systems
- excellent for curing high viscosity UV adhesives & coatings
- expected bulb life approximately 5,000 hours
- Type D UV Bulb



**UV Replacement Lamp - Ultracure 1000 and 2000**

**Part number: 102-051**

**Reference Part Number: ULTRAPT1000-H, ULTRA2000-H**

- electrode less type d bulb designed for use with Ultracure 1000 & 2000 UV Curing Systems
- excellent for curing high viscosity adhesives, clear-coats & finishes
- expected bulb life approximately 5,000 hours
- Type H UV Bulb



**50 ml Dual Cartridge Dispense Gun**

**Part number: 110-020**

**Reference Part Number: GUN0001**

- Manual operated dispensing gun for 50ml dual cartridge adhesives



**300 ml Cartridge Dispense Gun**

**Part number: 110-021**

**Reference Part Number: Gun0300-PA**

- Pneumatic dispensing gun for 300ml cartridges of adhesives & sealants



**400 ml Dual Cartridge Dispense Gun**

**Part number: 110-022**

**Reference Part Number: GUN0400**

- Manually operated dispensing gun for 400ml dual cartridge adhesives



**Pneumatic 400 ml 2 Part Dispense Gun**

**Part Number: 110-023**

**Reference Part Number: Gun0400-P**

- Pneumatic operated dispensing gun for 400 ml dual cartridges



**Dispensing pen without control switch**

**Part number : DISPENSE0002**

**Reference Part Number: DISPENSE0002**

- automated dispensing pen
- with male & female LUER-Lock ends
- For use with the Autobonder 2111

**NOTE #1:** Does not include dispense interconnect tubing



**Dispensing Pen without switch**

**Part number: DISPENSE0001**

**Reference Part Number: DISPENSE0001**

- Manual dispensing pen
- with male & female LUER-Lock ends
- for use with the Autobonder 2111

**NOTE #1:** Does not include dispense interconnect tubing



**Foot Pedal Control Unit**

**Part number: 110-009**

**Reference Part Number: ControlIPT0002**

- Foot pedal for use with the Autobonder precision dispensing systems



**30cc Syringe ADAPTER 0010**

**Part number: 104-003**

**Reference Part Number: 30cc Syringe ADAPTER 0010**

- 30cc Pnuematic syringe adaptor
- Use with HERNON 2101 Series Control



**3cc Syringe ADAPTER 0007**

**Part number:104-000**

**Reference Part Number: 3cc Syringe ADAPTER 0007**

- 3cc Pnuematic syringe adaptor
- Use with HERNON 2101 Series Control



**5cc Syringe ADAPTER 0008**

**Part number: 104-002**

**Reference Part Number: 5cc Syringe ADAPTER 0008**

- 5cc Pnuematic syringe adaptor
- Use with HERNON 2101 Series Control



**10cc Syringe ADAPTER 0009**

**Part number: 104-001**

**Reference Part Number: ADAPTER0009**

- 10cc Pnuematic syringe adaptor
- Use with HERNON 2101 Series Control



**Needle Adapter 1/8" NPT Thread**

Adaptor 1

**Part number: 101-023**

**Reference Part Number: ADAPTER0001**

- Polypropylene Needle Adapter
- 1/8" NPT/ 7/16 Hex/Male Luer Lock natural color



**Black Needle Adapter 1/8" NPT Thread**

Adaptor 2

**Part number: 101-024**

**Reference Part Number: ADAPTER0002**

- Black polypropylene needle adapter
- 1/8 NPT / 7/16 Hex/Male Luer Lock



**Needle Adapter 1/4" NPT Thread**

Adaptor 3

**Part number: 101-025**

**Reference Part Number: ADAPTER0003**

- Polypropylene needle Adapter
- 1/4 NPT/ 9/16 Hex/Male Luer Lock natural color



**Black Needle Adapter 1/4" NPT Thread**

Adaptor 4

**Part number: 101-026**

**Reference Part Number: ADAPTER0004**

- Black polypropylene needle adapter
- 1/4 NPT/ 9/16 Hex/Male Luer Lock



**Needle Adapter 10-32 Thread**

Adaptor 14

- Male LUER integral lock ring to 10-32 special tapered thread

**Part Number: 101-027**

**Reference Part Number: ADAPTER014**

- White nylon



**Needle Adapter 1/4 - 28 Thread**

Adaptor 15

- Male LUER integral lock ring to 1/4-28 UNF Thread

**Part Number: 101-048**

**Reference Part Number: ADAPTER015**

- White Nylon



**Tube Adapter for Auto sealer 2600**

**Part number: ADAPTER2600-48**

- Tube Adapter for Auto sealer 2600



**1/4" NPT x 1/2 tube Kynar Fittings**

**Part number: 101-042**

**Reference Part Number: FIT1/4-50**

- 1/4" NPT x 1/2 tube Kynar Fittings





**Adapter -1/8" NPT x 1/4" tube Kynar Fittings**

**Part number: 101-043**

**Reference Part Number: FIT1/4-50**

- 1/8" NPT x 1/4" TUBE KYNAR FITTINGS



**1/4" NPT X 1/2" Tube X 90° Kynar Fitting**

**Part number:101-044**

**Reference Part Number: FIT1/4-50**

- 1/4" NPT X 1/2" Tube X 90° Kynar Fitting



**1/4" NPT X 3/8" Tube X 90° Kynar Fitting**

**Part Number: 101-045**

**Reference Part Number: FIT 1/4x 37-90**

- 1/4" NPT X 3/8" Tube X 90° Kynar Fitting



**1/8" NPT X 1/4" Tube X 90° Kynar Fitting**

**Part number: 101-046**

**Reference Part Number: FIT1/4-50-90**

- 1/8" NPT X 1/4" Tube X 90° Kynar Fitting



**1/4" NPT X 1/4" Tube X 90° Kynar Fitting**

**Part Number: 101-047**

**Reference Part Number: FIT1/4-50-90**

- 1/4" NPT X 1/4" Tube X 90° Kynar Fitting



**Male connector with barb and quick disconnect CONNECT0027-SS**

**Part Number: 101-013**

**Reference Part Number: CONNECT0027-SS**

- Male connector with barb and quick disconnect



**1/4" stainless steel female compression connector**

**Part Number: 101-028**

**Reference Part Number: CONNECT0027-SS**

- 1/4" stainless steel female compression connector



**Male quick disconnect X 1/8" NPT**

**Part Number: 101-029**

**Reference Part Number: CONNECT0031**

- Male quick disconnect X 1/8" NPT



**Valve Dispensing Valve Stand**

**Part number: 110-039**

**Reference Part Number: SS-2200-30**

- Fully adjustable stand
- Designed for use with the Sureshot 2200 valves/ 10-32 mounting



**Valve Dispensing Stand**

**Part number: 110-040**

**Reference Part Number: SS-2200-30/4000**

- Fully adjustable stand
- Designed for use with Sureshot 4000 Valve Dispensing Systems or 1/8" NPT MNT



**Syringe/Valve Stand**

**Part number: 106-045**

**Reference Part Number: 2101-25**

- Designed for use with the Sureshot 2200



**1-8 Adhesive Manifold 1/16**

**Part number: MANIFOLD0008**

**Reference Part Number: MANIFOLD0008**

- 1-8 Adhesive Manifold 1/16
- Fits sizes 1/16"-



**Dispensing Tubing**

**Part number:101-033**

**Reference Part Number: HOSE0004**

- White Teflon material feed tubing
- 1/4" OD X .15" ID
- Sold by the foot



**Dispensing Tubing**

**Part number: 101-034**

**Reference Part Number: HOSE0005**

- 3/8" OD Teflon
- Sold by the foot



**Nylon Black Tubing**

**Part number: 101-035**

**Reference Part Number: HOSE0006**

- 1/8" OD X .08" ID
- Sold by the foot



**Nylon Black Tubing**

**Part number:101-037**

**Reference Part Number: HOSE0007**

- 4mm OD X 2.7mm ID
- Sold by the foot



**Nylon Black Tubing**

**Part number: 101-036**

**Reference Part Number: HOSE0008**

- 1/4" OD X .175" ID
- Sold by the foot



**Black Teflon Liners Tubing**

**Part number: 101-038**

**Reference Part Number: HOSE0009**

- 1/4" OD X 3/16" ID
- Sold by the foot
- 100 PSI max



**Dispense Tubing Adapter**

**Part number: 101-039**

**Reference Part Number: HOSE0011**

- 18" Teflon clear fluid line with male & female LUER- Lock connectors



**Dispense Tubing Adapter**

**Part number: 101-040**

**Reference Part Number: HOSE0012**

- 24" Teflon clear fluid line with male & female LUER-



**Dispense Tubing Adapter**

**Part number: 101-041**

**Reference Part Number: HOSE0013**

- 36" Teflon clear fluid line with male & female LUER-Lock connectors



**R125 O Ring Seal**

**Part Number: GASKET0009**

- solvent-resistant lid gasket for Reservoir 125



**30cc Syringe O Ring**

**Part Number: Gasket030**

- Buna n o-ring seal for 30 cc syringe pressure cap



**Reservoir gasket 20**

**Part Number: GASKET0020**

- solvent-resistant lid gasket for Reservoir 20



**R125 Liners**

**Part Number: 107-013**

**Reference Part Number: R125-5PB**

- 1 gallon reservoir liner
- sold in pack of 5



**R150 Liners**

**Part Number: DISPENSE0002**

- 2 1/2 gallon reservoir liner
- use with reservoir 11



**R125 RESERVOIR**  
**PART NUMBER: 110-100**  
**REFERENCE PART NUMBER: R125**

- 1 GALLON CAPACITY PRESSURE RESERVOIR.
- 0-100 PSI (7BAR)
- CHAMBER SIZE: 5 3/4 ID X 10" DP
- INCLUDES 100 PSI SAFETY PRESSURE RELEASE VALVE AND 2 LINERS
- TUBING NOT INCLUDED
- 2 DISPENSE PORTS 1/4" NPT. (ONE PORT PLUGGED)
- 1 FLUID LEVEL SENSOR PORT
- SEE REGULATOR OPTIONS / SELECTION CHART
- SEE DISPENSE TUBE FITTING OPTION / SELECTION CHART
- SEE LEVEL SENSOR OPTIONS / SELECTION CHART



## REGULATOR OPTIONS PICK ONE



SHOWN ASSEMBLED

**STANDARD REGULATOR KIT (0-30 PSI)**  
**PART NUMBER: 110-080**

- Standard pressure regulator (0-30 psi) 1/4" npt.
- Standard pressure gauge (0-30 psi) 1/8" npt.
- Quick disconnect nipple / male 1/4" npt.
- Hex long nipple 2" pipe size 1/4" npt



SHOWN ASSEMBLED

**STANDARD REGULATOR KIT (0-100 PSI)**  
**PART NUMBER: 110-081**

- Standard pressure regulator (0-100 psi) 1/4" npt.
- Standard pressure gauge (0-100 psi) 1/8" npt.
- Quick disconnect nipple / male 1/4" npt.
- Hex long nipple 2" pipe size 1/4" npt



SHOWN ASSEMBLED

**PRECISION REGULATOR KIT (0-30 PSI)**  
**PART NUMBER: 110-090**

- Precision pressure regulator (0-30 psi) 1/8" npt.
- Standard pressure gauge (0-30 psi) 1/8" npt.
- Quick disconnect nipple / male 1/8" npt, 1/4" universal disconnect.
- Hex long nipple 2" pipe size 1/8" npt.
- Brass 1/4" npt male x 1/8" npt female reducer bushing.



SHOWN ASSEMBLED

**PRECISION REGULATOR KIT (0-100 PSI)**  
**PART NUMBER: 110-091**

- Precision pressure regulator (0-100 psi) 1/4" npt.
- Standard pressure gauge (0-100 psi) 1/8" npt.
- Quick disconnect nipple / male 1/4" npt.
- Hex long nipple 2" pipe size 1/4" npt

**DISPENSE TUBE FITTING  
PICK ONE OR TWO**



**1/8" DISPENSE TUBE FITTING  
STOCK # 101-055**

- THERMOCOUPLE 1/4" NPT MALE x 1/8" TUBE
- 316 STAINLESS STEEL
- THERMOCOUPLE – THRU. TUBE FITTING



**1/4" DISPENSE TUBE FITTING  
STOCK # 101-028**

- THERMOCOUPLE 1/4" NPT MALE x 1/4" TUBE
- 316 STAINLESS STEEL
- THERMOCOUPLE – THRU. TUBE FITTING



**3/8" DISPENSE TUBE FITTING  
STOCK # 101-053**

- THERMOCOUPLE 1/4" NPT MALE x 3/8" TUBE
- 316 STAINLESS STEEL
- THERMOCOUPLE – THRU. TUBE FITTING

# SENSOR OPTIONS PICK ONE

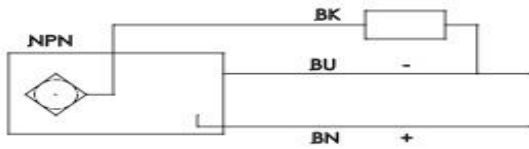

**NPN LEVEL SENSOR**  
**PART NUMBER: 110-095**

- SENSOR CAPACITIVE (NPN).
- 3 WIRES CONNECTOR
- 5 METER CABLE EXTENSION
- SENSOR ADAPTOR PORT

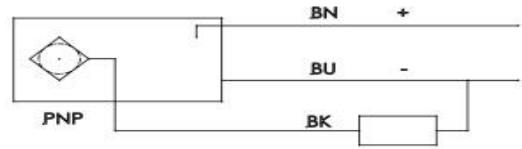

**PNP LEVEL SENSOR**  
**PART NUMBER: 110-096**

- SENSOR CAPACITIVE (PNP).
- 3 WIRES CONNECTOR
- 5 METER CABLE EXTENSION
- SENSOR ADAPTOR PORT.

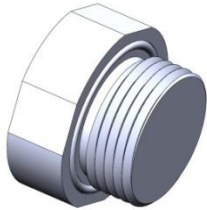

**NO SENSOR**  
**PART NUMBER: 110-097**

- SENSOR PORT PLUG



**R150 Reservoir**  
**Part number: 110-028**

**Reference Part Number: R150**

- 2.5 gallon capacity pressure reservoir
- Includes Pressure Release Valve, Dispense Tubing &
- Includes Pressure Release Valve, Dispense Tubing & Connectors
- Standard price shown, see precision regulator option for price increase/options on Reservoir Selection Chart
- **NO TUBING INCLUDED**
- **29 lbs**



**R175 Reservoir**  
**Part Number: R175**

**Reference Part Number: R175**

- 3 gallon 316 S.S. Reservoir w/regulation 0-100 PSI Reg/Gauge 100 PSI Safety
- Standard price shown, see precision regulator option for price increase/options on Reservoir Selection Chart
- **NO TUBING INCLUDED**



**R200 Reservoir**  
**Part number: R200**

**Reference Part Number: R200**

- 10 gallon pressure tank
- including pressure release valve, dispense tubing & air connectors
- regulators and pressure gauge optional
- Standard price shown, see precision regulator option for price increase/options on Reservoir Selection Chart
- **NO TUBING INCLUDED**



**850 ml Cartridge Retainer**

**Part Number: 110-056**

**Reference Part Number: RETAINER0032**

- Retainer for 850ml cartridges
- Includes body, cap, o-ring & pressure gauge
- 0-100 PSI Regulator



**1/10 Gallon/300 ml Cartridge Retainer**

**Retainer 0300 ml**

- Includes plastic cap/seals, Metal tube cartridge holder
- 48" of 1/4" Diameter Tubing W/ male CPC Connector



**6 oz Cartridge Retainer**

**Part Number: 110-055**

**Reference Part Number: RETAINER0006**

- 6 oz cartridge retainer for Autobonder 2101
- Constructed of heavy gauge drawn metal
- Includes body, cap, & disconnect coupling



**14 Gauge**

**Part Number: 104-006**

- 14 gauge needle with stainless steel tip
- Green
- Pack Of 20



**14 Gauge 1/4" Long**

**Part Number: 104-033**

- 14 gauge needle with stainless steel tip
- 1/4" long needle
- Green
- Pack Of 20

**End user cost**



**15 Gauge**

**Part Number: 104-007**

- 15 Gauge needle with stainless steel tip
- Amber
- Pack Of 20



**16 Gauge**

**Part Number: NDL07**

- 17 gauge needle with stainless steel tip
- Violet
- pack Of 20



**18 Gauge**

**Part Number: 104-008**

- 18 Gauge needle with stainless steel tip
- Green
- Pack Of 20



**20 Gauge**

**Part Number: 104-009**

- 20 gauge needle with stainless steel tip
- Pink
- Pack Of 20



**21 Gauge**

**Part Number: 104-010**

- 21 gauge needle with stainless steel tip
- Purple
- Pack Of 20



**22 Gauge**

**Part Number: 104-011**

- 22 gauge needle with stainless steel tip
- Blue
- Pack Of 20



**23 Gauge**

**Part Number: 104-012**

- 23 Gauge needle with stainless steel tip
- Orange
- Pack Of 20



**25 Gauge**

**Part Number: 104-013**

- 25 gauge needle with stainless steel tip
- Red
- pack Of 20



**27 Gauge**

**Part Number: 104-014**

- 27 Gauge needle with stainless steel tip
- Clear
- Pack Of 20



**30 Gauge**

**Part Number: 104-015**

- 30 Gauge needle with stainless steel tip
- Dark Pink
- Pack Of 20





**NEEDLERSS14**

**Part number: NEEDLERSS14**

- 14 gauge reusable needle
- stainless steel
- sold per piece



**part number: RC-NEEDLE14SS**

- Green 14 gauge
- Sold 5 needles per package



**part number: RC-NEEDLE14SS-TL**

- Green 14 gauge
- Teflon
- .038 ID
- Sold 5 needles per package



**part number: RC-NEEDLE15SS**

- Green 15 gauge
- Sold 5 needles per package



**part number: RC-NEEDLE16SS**

- Green 16 gauge
- Sold 5 needles per package



**Part Number: 104-026**

**Reference Part Number: RC-NEEDLE18SS**

- Green 18 gauge
- Sold 5 needles per package



**Part Number: 104-027**

**Reference Part Number: RC-NEEDLE21SS**

- Green 21 gauge
- Sold 5 needles per package



**Part Number: 104-028**

**Reference Part Number: RC-NEEDLE23SS**

- Green 23 gauge
- Sold 5 needles per package



**part number: RC-NEEDLEKIT0004**

- One each of the 23SS, 21SS, 18SS, 16SS, 15SS, 14SS
- Sold 5 needles per package



**14 Gauge Microtip**

**Part Number: 104-018**

- 14 Gauge disposable plastic micro tip
- Green
- Pack of 20



**16 Gauge Microtip**

**Part Number: 104-019**

- 16 Gauge disposable plastic
- Grey
- Pack of 20



**18 Gauge Microtip**

**Part Number: 104-020**

- 18 Gauge disposable plastic
- Green
- Pack of 20



### 20 Gauge Microtip

**Part Number: 104-021**

- 20 Gauge disposable plastic
- Pink
- Pack of 20



### 22 Gauge Microtip

**Part Number: 104-022**

- 22 Gauge disposable plastic
- Light Blue
- Pack of 20



### 25 Gauge

**Part Number: 104-023**

- 25 Gauge disposable plastic
- Red
- Pack of 20



### Static Mixers

**Part Number: 104-029**

**Reference Part Number: STATIC0001**

- twist-lock static mixer for 50ml dual component adhesives
- 6" length, 6.3 mm diameter
- 21 elements
- 1:1, 2:1 & 4:1 Mix Ratio



**Static Mixer for 300 ml & 400 ml dual component adhesives**

**Part Number: 104-030**

**Reference Part Number: STATIC0002**

- 9.25 length, 6 mm diameter
- 32 elements
- 1:1 & 2:1 mix ratio



**Pinch-tube static mixer for 400 ml dual component adhesives & Autobonder 2040**

**Part Number:**

**Reference Part Number: STATIC0003**

- Pinch-Tube Static Mixer for 400 ml Dual Component Adhesives & Autobonder 2040
- 11" length, 6 mm diameter, 32 elements
- 1:1 Mix Ratio



**Syringes 30 cc Syringe with Plunger**

**Part Number: 104-025**

**Reference Part Number: SYR0024**

- Syringes 30 cc Syringe with Plunger
- Amber: Transparent and shielding



**TIP0003**

**Part number: TIP0003**

- 4" PLASTIC DISPENSING TIP- 1/4"X 4" NPT Dispensing tip White



**TIP0006**

**Part number: TIP0006**

- 2 1/2" Plastic Dispensing Tip-1/4" NPT Dispensing tip White
- White



**Luer-Lock Cap**

**Part number: 104-005**

**Reference Part Number: TIP0014**

- lock cap
- orange
- pack of 10



**Needle Kit**

**Part number: 110-033**

**Reference Part Number: NEEDLEKIT0002**

- Needle Evaluation kit
- Includes 2 of each
- Needle Gauges  
14, 15, 16, 17, 18, 20, 21, 22, 24, 25, 26
- Microtips Gauges  
14, 16, 18, 20, 22, 24